



LAN interconnecting devices

INTRODUCTION

- LANs do not normally operate in isolation. They are connected to one another or to the Internet.
- To connect LANs, connecting devices are needed.
- Connecting devices are such as bridge, switch, router, hub, repeater.

CONNECTING DEVICES

We divide connecting devices into different categories based on the layer in which they operate in a network.

- Passive Hubs
- Active Hubs
- Bridges
- Two-Layer Switches
- Routers
- Three-Layer Switches
- Gateways

Five categories of connecting devices

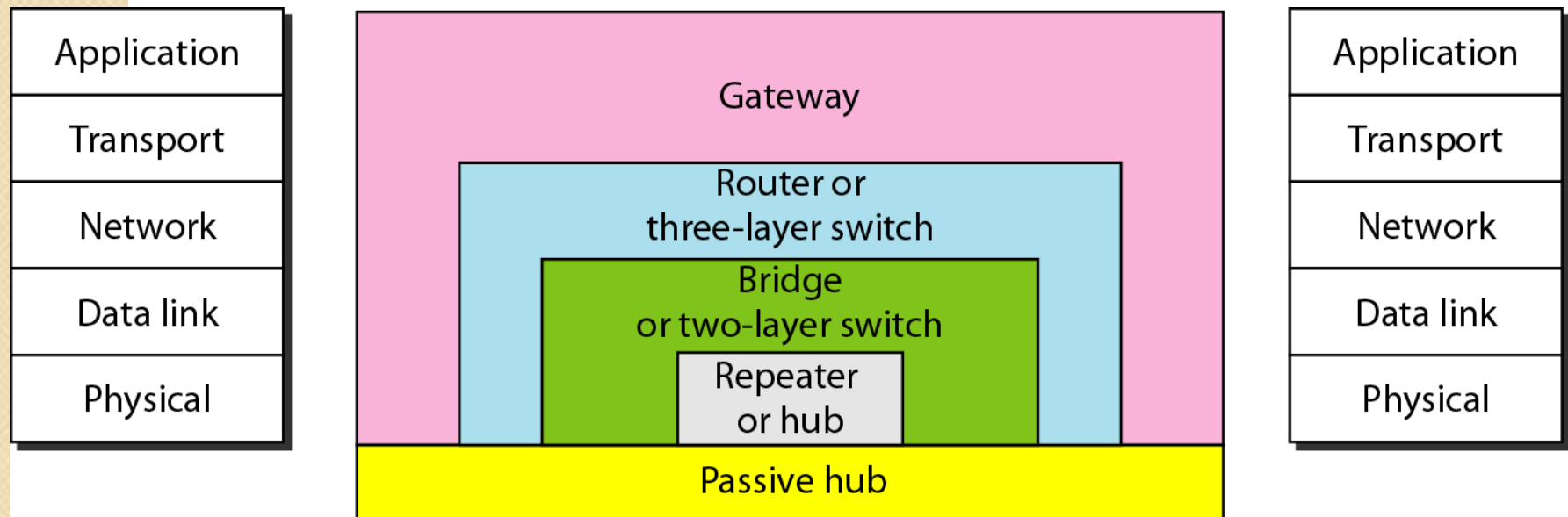

PASSIVE HUB

- A passive hub is just a connector. It connects the wires coming from different branches.



REPEATERS

- A repeater is a device that operates only at the PHY layer.
- Repeater strengthen the signal and turn it to be the original bit pattern.
- A repeater can extend the physical length of LAN by connecting it.
- Take note that a repeater is not device that can connect two LANs of different protocols.

A repeater connecting two segments of a LAN

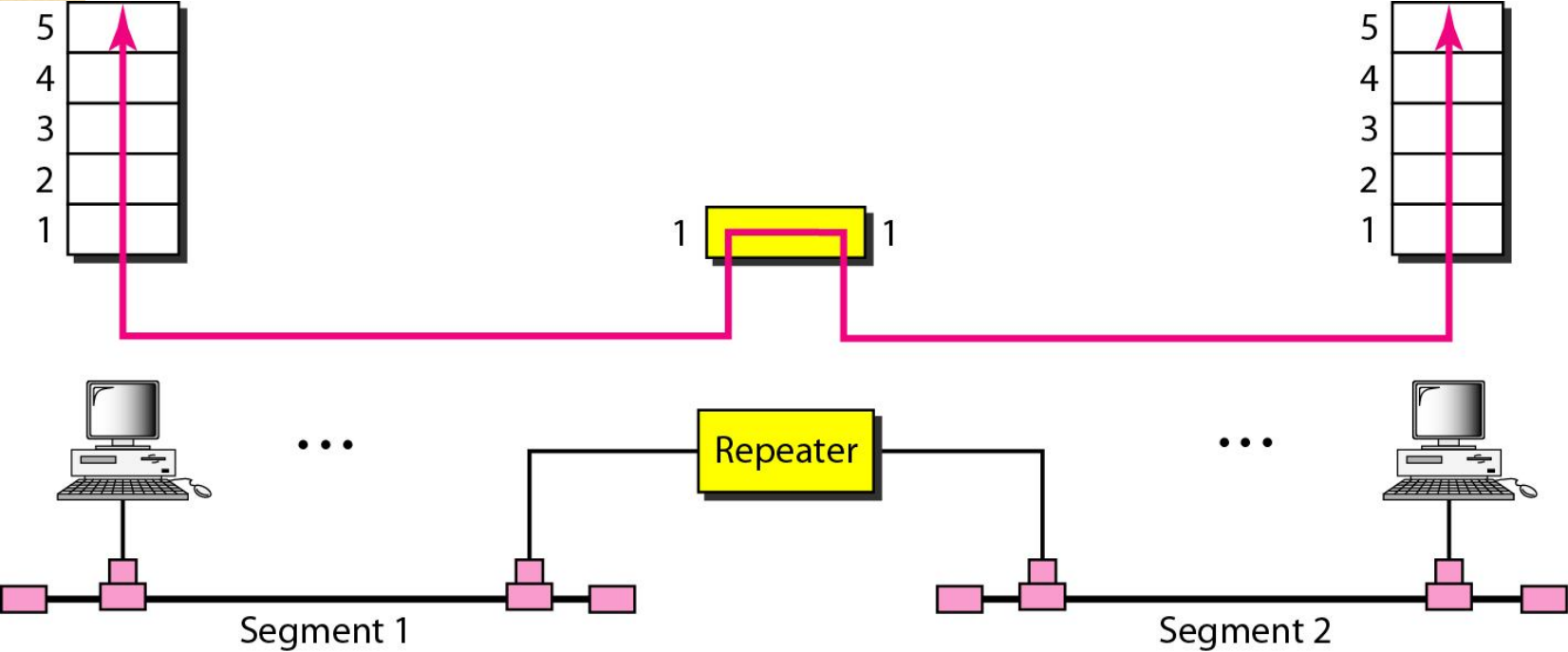



Note

A repeater connects segments of a LAN.



Note

A repeater forwards every frame;
it has no filtering capability.



Note

A repeater is a regenerator,
not an amplifier.

Function of a repeater

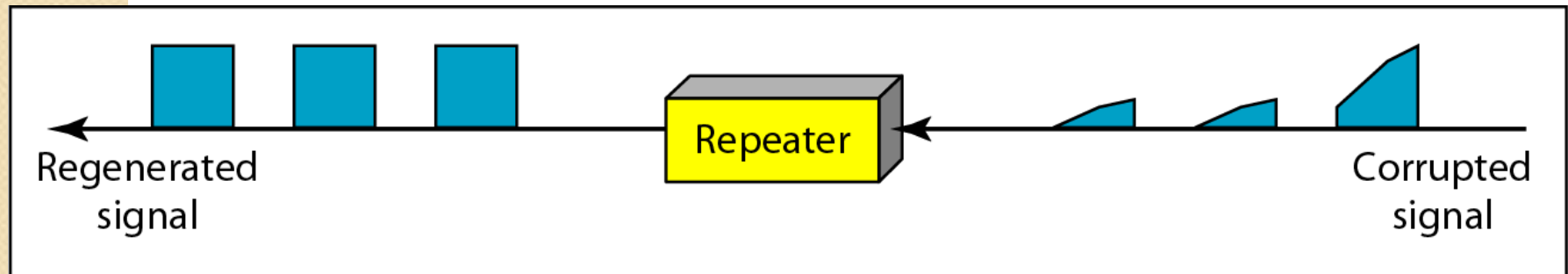

a. Right-to-left transmission.

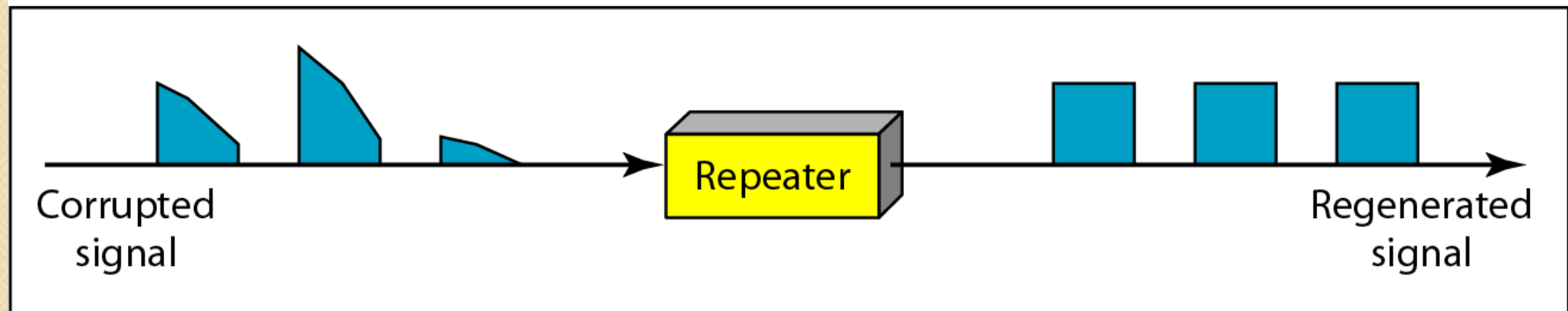

b. Left-to-right transmission.

Booster/ Wireless signal Extender



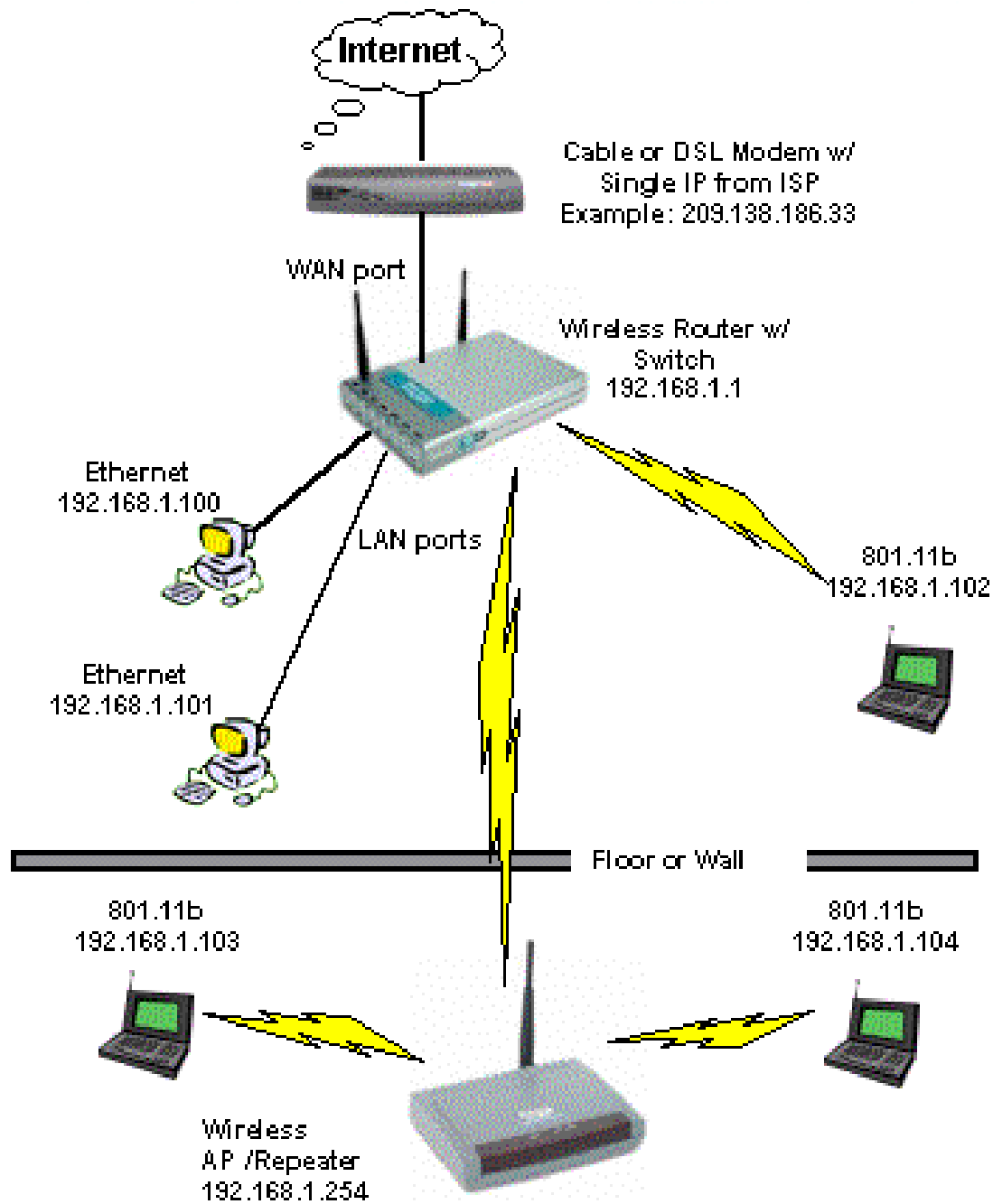

DIFF TYPE REPEATER/OUTSIDE



A. GSM Frequency shift repeater



B. Optical fiber repeater

ACTIVE HUB / JUST SIMPLY CALL 'HUB'

- An active hub is actually a multiport repeater
- Normally used to create connections between stations in a physical star topology.
- Refer previous Ethernet implementation 10Base-T
- Can also create multiple level of hierarchy



A hierarchy of hubs

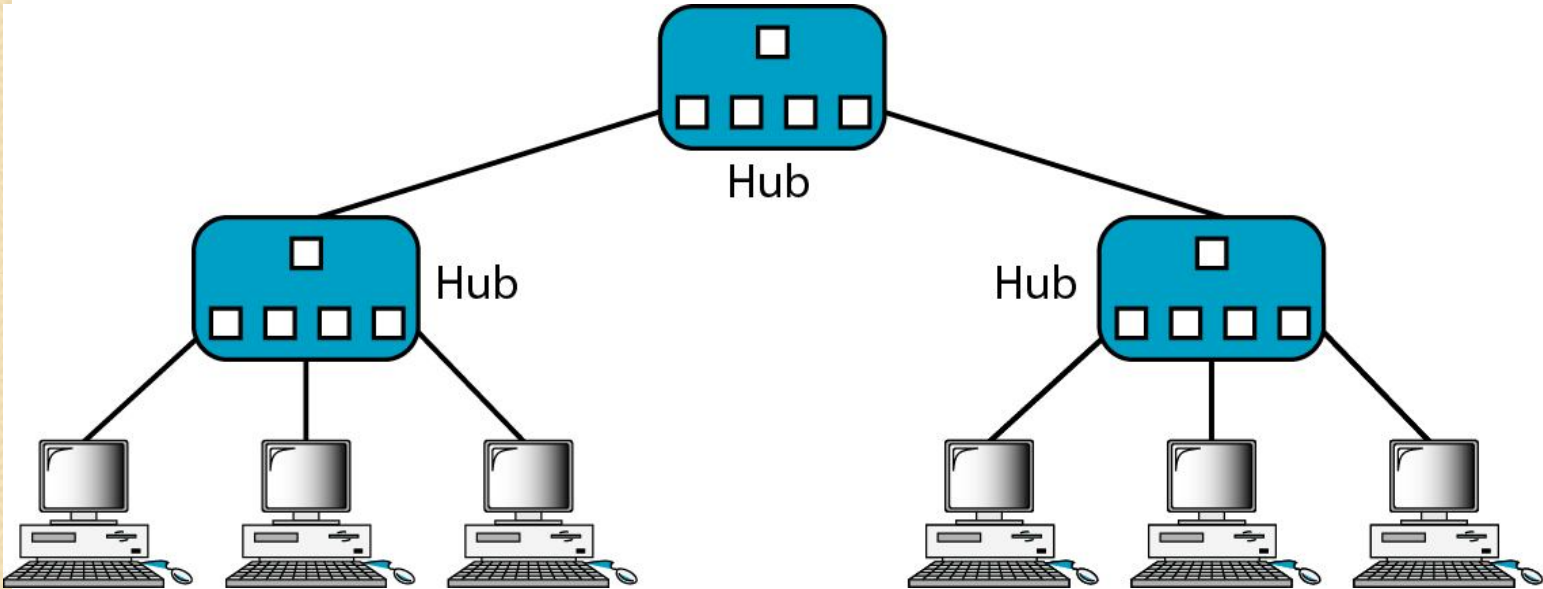

BRIDGES

- Operates in both the PHY and the data link layer.
- As a PHY layer device, it regenerates the signal it receives.
- As a data link layer device, the bridge can check the PHY/MAC addresses (source and destination) contained in the frame.



Note

A bridge has a table used in filtering decisions.

- It can check the destination address of a frame and decide if the frame should be forwarded or dropped.
- If the frame is to be forwarded, the decision must specify to port.
- A bridge has a table that maps address to ports.

A bridge connecting two LANs

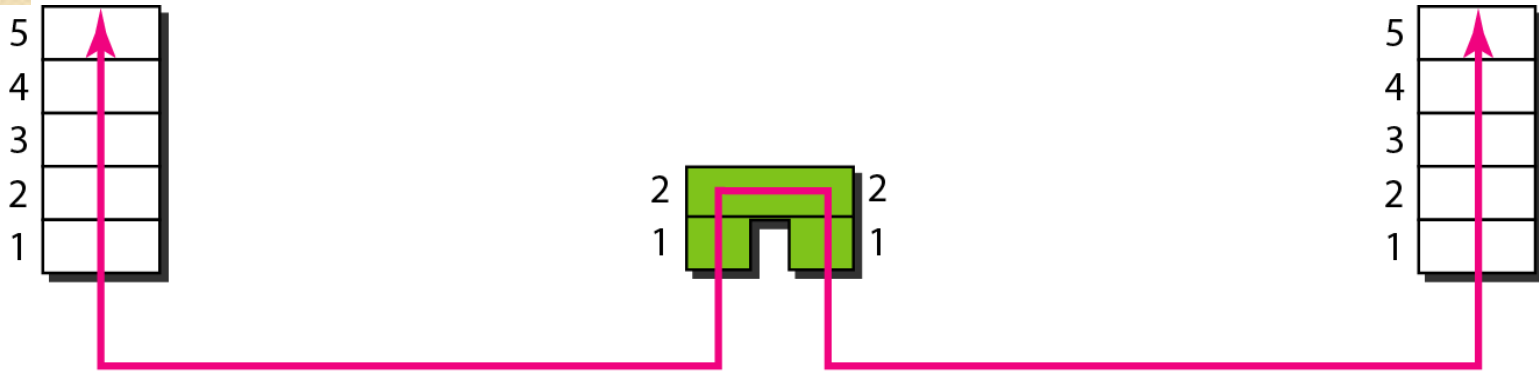

Address	Port
71:2B:13:45:61:41	1
71:2B:13:45:61:42	1
64:2B:13:45:61:12	2
64:2B:13:45:61:13	2

Bridge Table

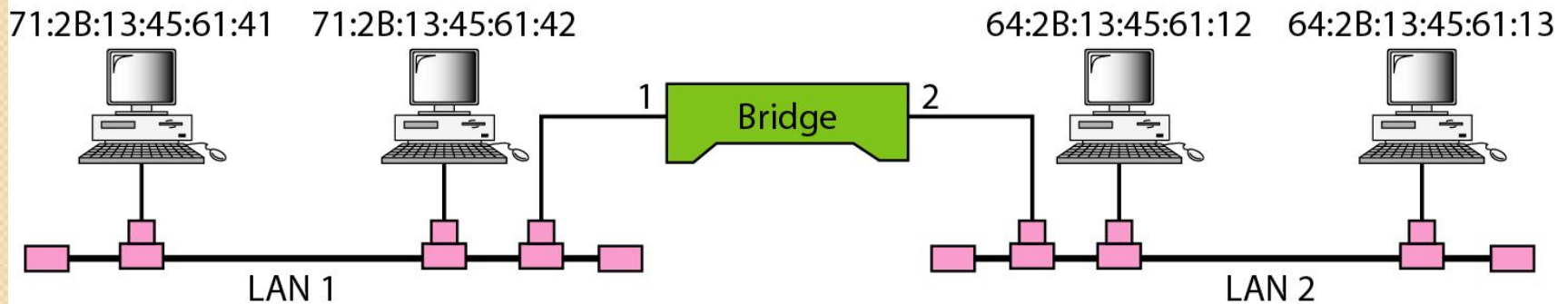

Note

A bridge does not change the physical (MAC) addresses in a frame.



Bridge with Netgear brand

TWO AND THREE LAYER SWITCHES

- Two layer switch operate at PHY and data link layer
- Three layer switch operates at network layer
- Bridge is an example of two-layer switch.
- Bridge with few port can connect a few LANs
- Bridge with many port may be able to allocate a unique port to each station, with each station on its own independent entity. This means no competing traffic (no collision as we saw in Ethernet)

THREE LAYER SWITCHES

- E.g. router.
- Routes packets based on their logical addresses (host-to-host addressing)
- A router normally connects LANs and WANs in the Internet and has a routing table that is used for making decision about the route. See figure
- The routing tables are normally dynamic and are updated using routing protocols.

Routers connecting independent LANs and WANs

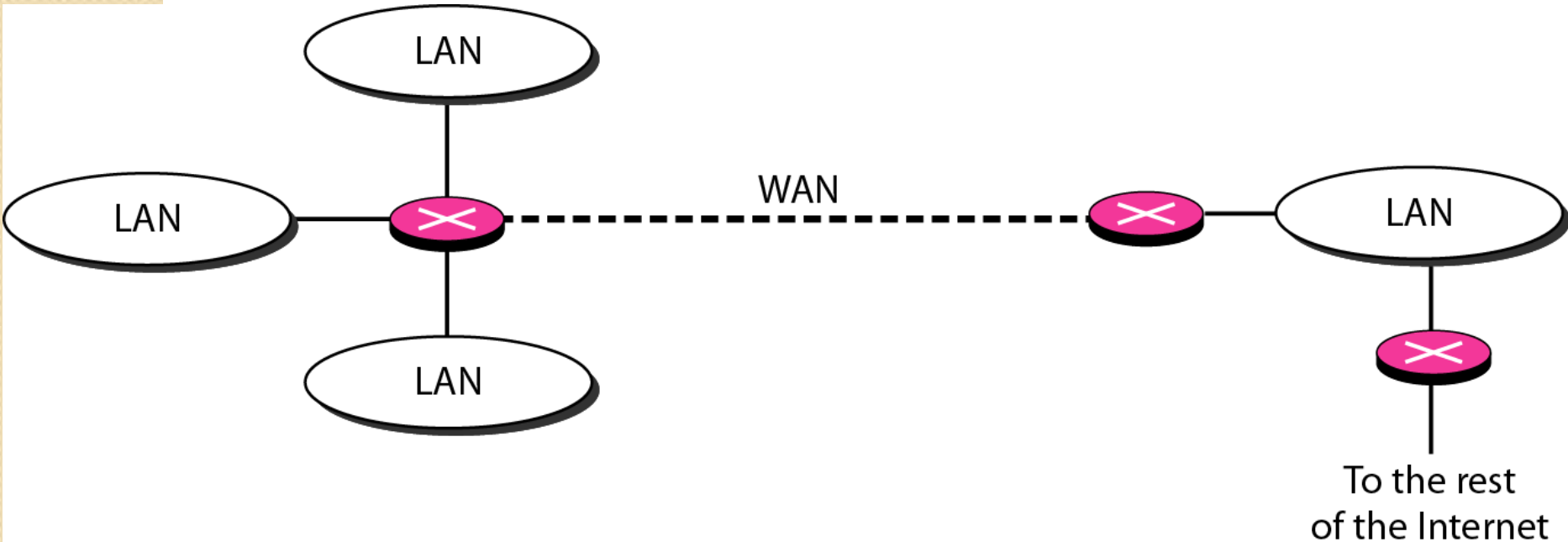

GATEWAY

- Interchangeably used term router and gateway
- Operates in all 5 layer of the Internet (TCP/IP) and 7 layers of OSI model
- A gateway takes an application message, reads it, and interprets it
- Broadband-modem-router is one e.g. of gateway

BACKBONE NETWORKS

A backbone network allows several LANs to be connected. In a backbone network, no station is directly connected to the backbone; the stations are part of a LAN, and the backbone connects the LANs.

- Bus Backbone
- Star Backbone
- Connecting Remote LANs



Note

In a bus backbone, the topology of the backbone is a bus.

Normally used as a distribution backbone to connect different building in an organization

Bus backbone

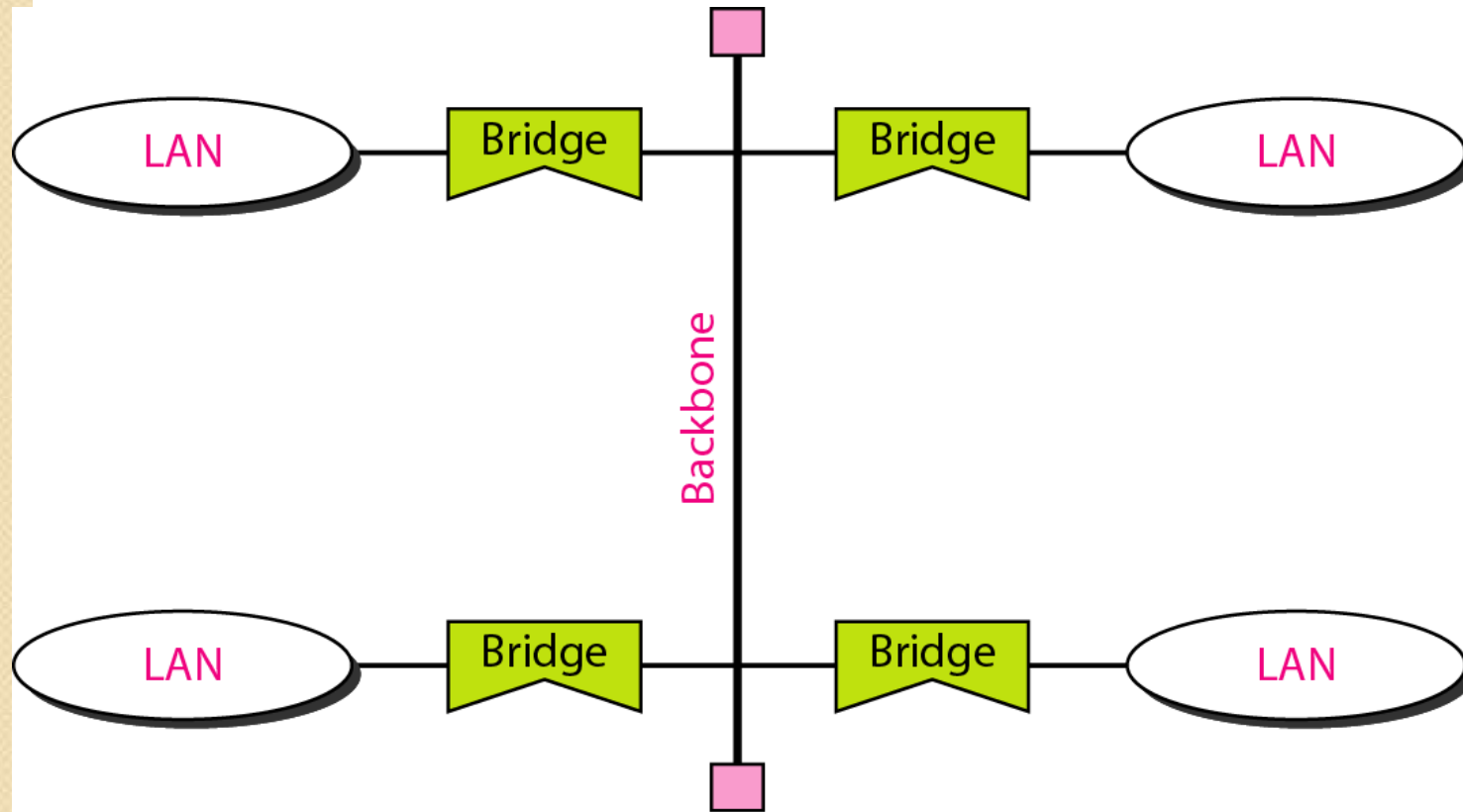



Note

In a star backbone, the topology of the backbone is a star;
the backbone is just one switch.

Used as a distribution backbone inside a building

Star backbone

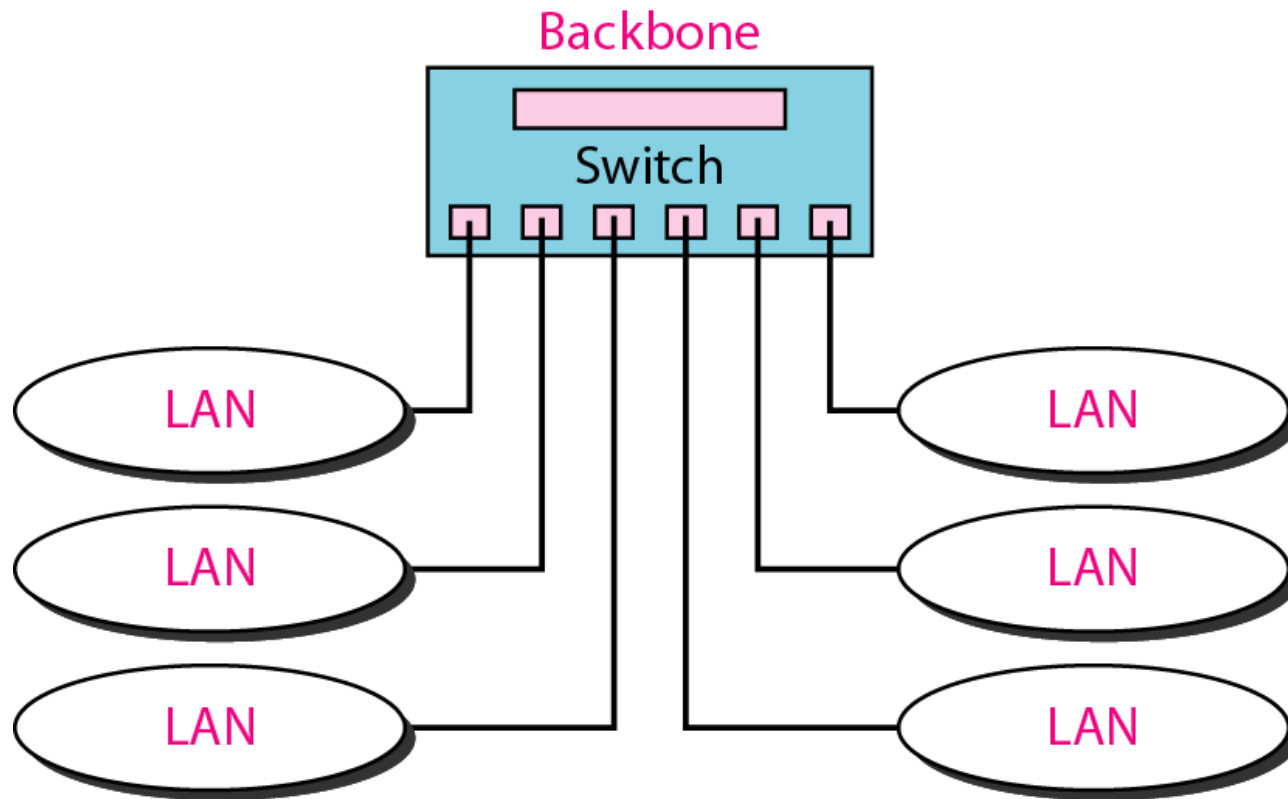

CONNECTING REMOTE LANs WITH BRIDGES

- LANs are far away from each other for e.g. when a company has several offices with LANs and needs to connect them.
- Involve PSTN with ADSL lines or leased telephone lines (analog)
- Bridge that connect these LANs are called remote bridge

Connecting remote LANs with bridges

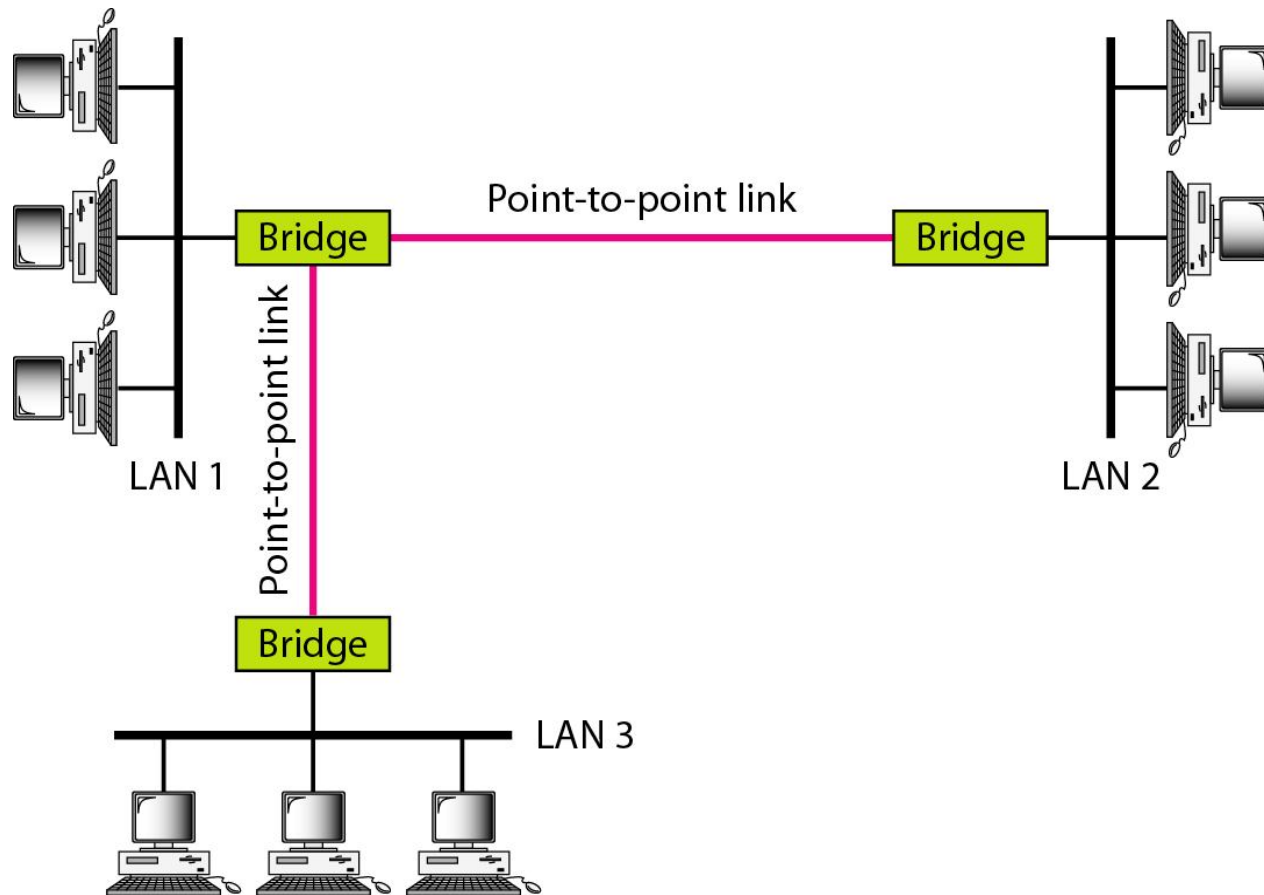



Note

A point-to-point link acts as a LAN in a remote backbone connected by remote bridges.

From Computer Desktop Encyclopedia
© 2000 The Computer Language Co. Inc.

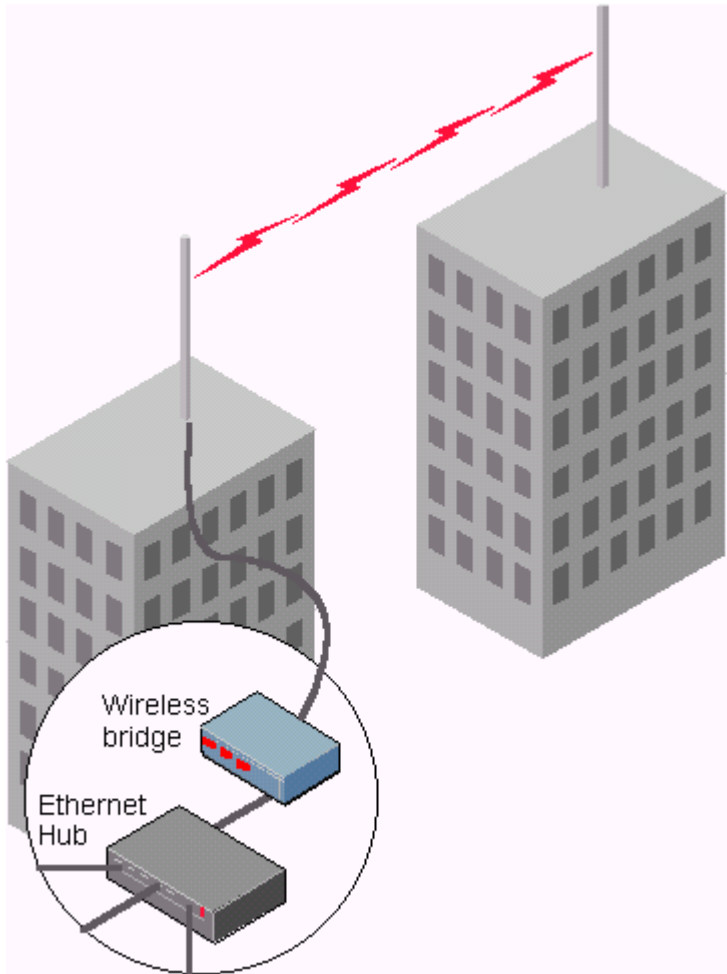

VIRTUAL LANs

*We can roughly define a **virtual local area network (VLAN)** as a local area network configured by software, not by physical wiring.*

A switch connecting three LANs

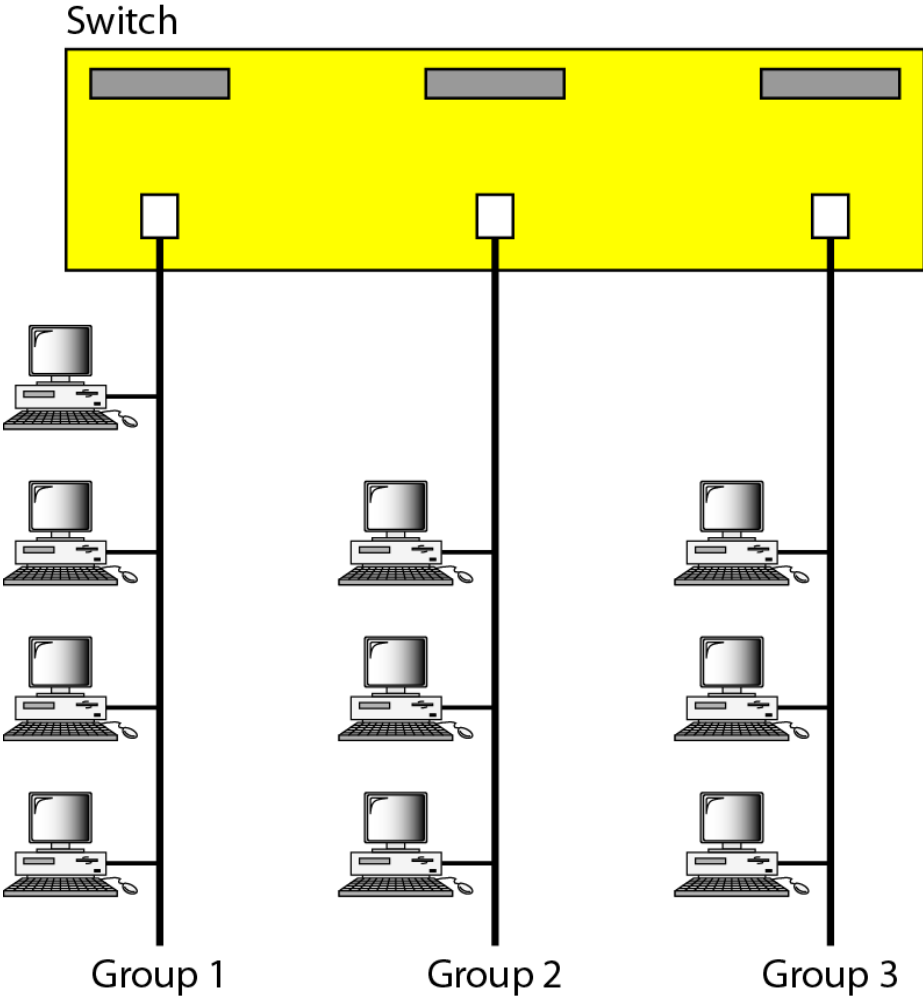

A switch using VLAN software

Switch with VLAN software

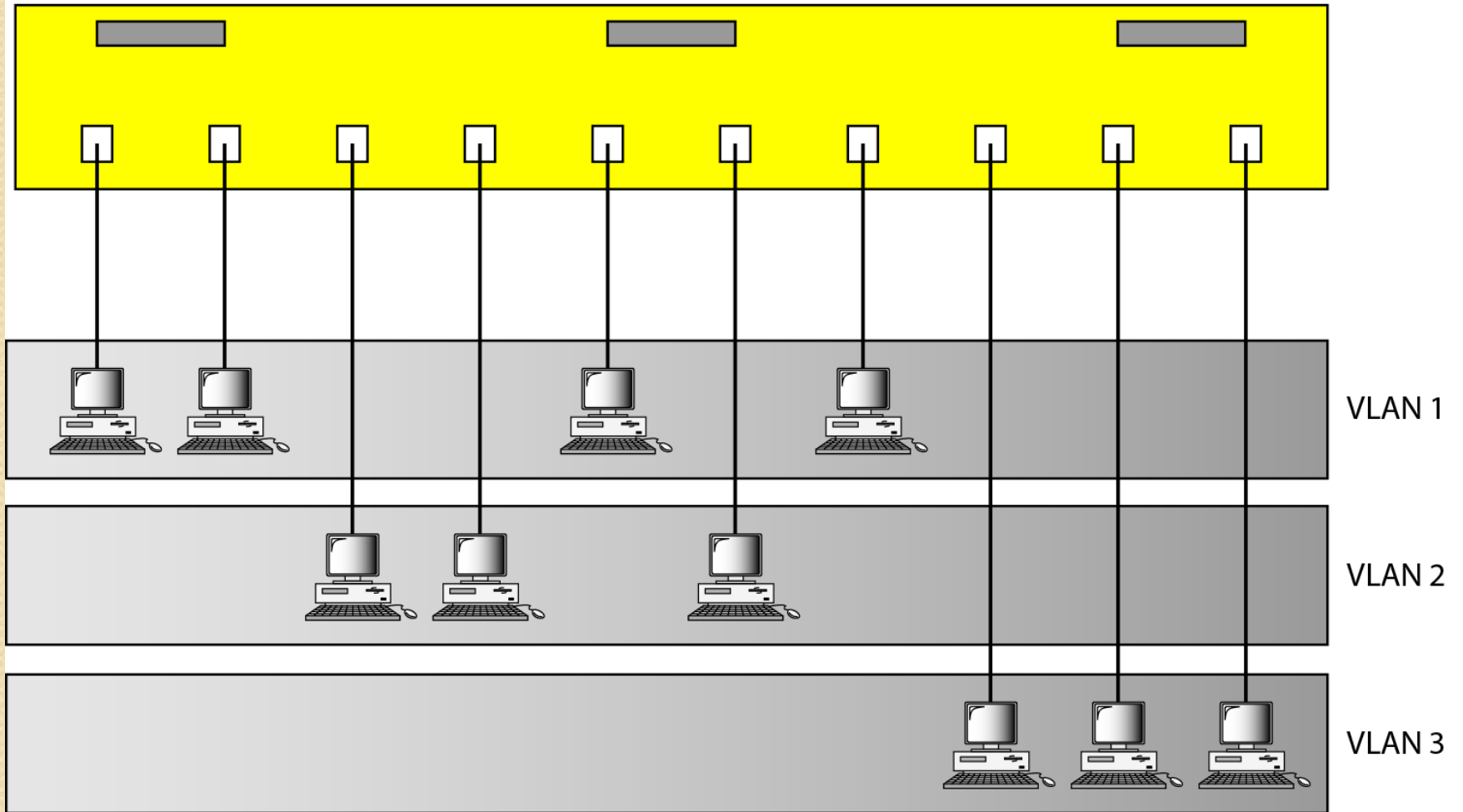



Note

VLANs create broadcast domains.

VIRTUAL LAN CONCEPT

- A virtual local area network, virtual LAN or VLAN, is a group of hosts with a common set of requirements, which communicate as if they were attached to the same broadcast domain, regardless of their physical location. A VLAN has the same attributes as a physical local area network (LAN), but it allows for end stations to be grouped together even if not on the same network switch.
- VLAN membership can be configured through software instead of physically relocating devices or connections. Most enterprise-level networks today use the concept of virtual LANs(VLAN). Without VLANs, a switch considers all interfaces on the switch to be in the same broadcast domain.

APPLICATIONS

- To find out the practical application of each device and VLAN is an assignment for students

SCOPE OF RESEARCH

- Routers based on route optimization algorithms in IPv6.
- Intelligent layer2 and layer3 devices

ASSIGNMENT

- List applications of each network device covered in lecture.
- What are the applications of VLANs?